

ANGLE	ULTIMATE CAPACITY = V_u
P-08	96.07 K
P-08A	136.40 K
P-08B	181.80 K

ISSUED: 08/07/08 REVISED:





STANDARD DESCRIPTION:

Joist Girder Pocket

DETAIL NO.:

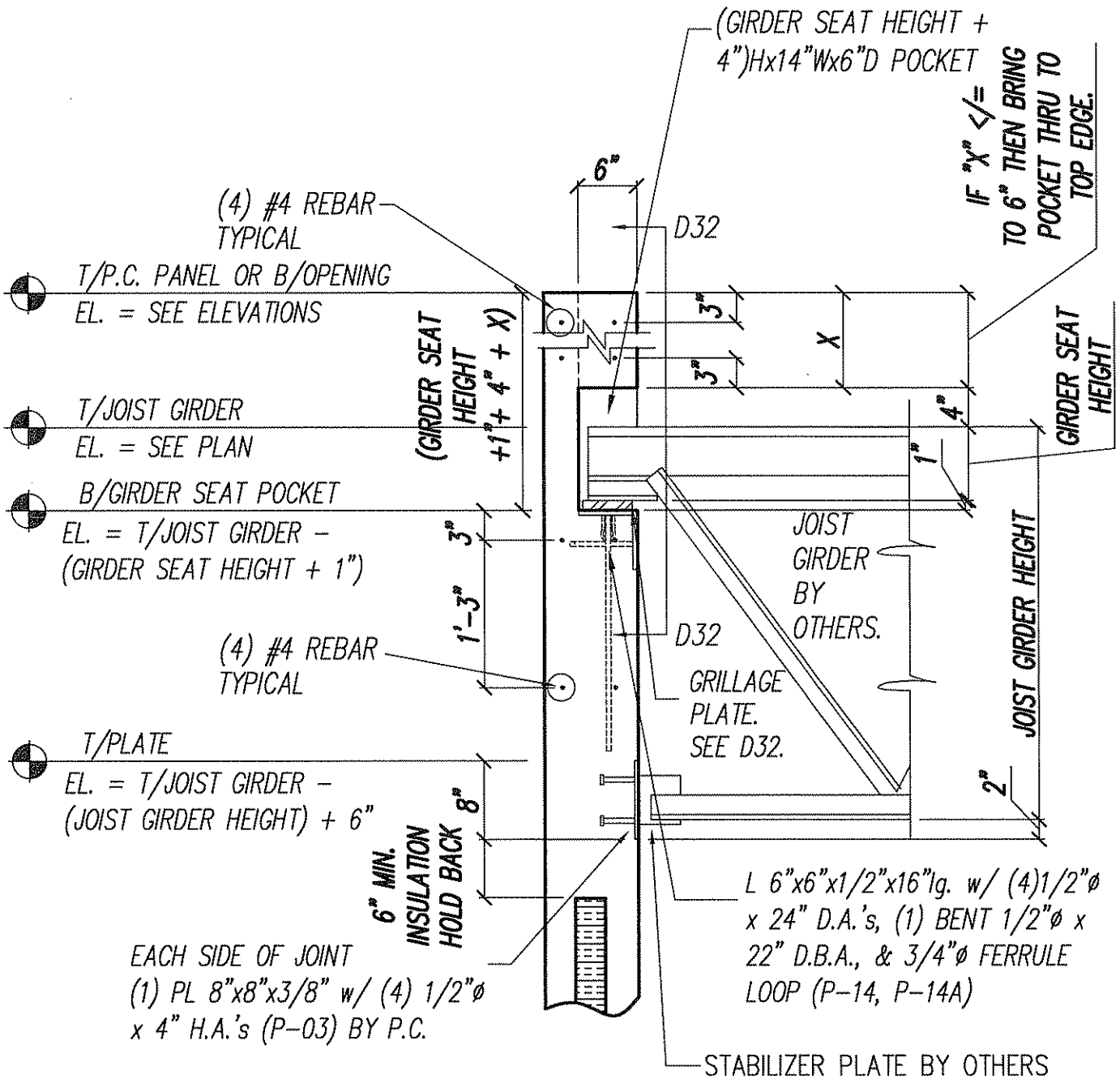
D30



ISSUED: 08/22/08 REVISED: 

STANDARD DESCRIPTION:

Joist Girder Pocket @ Joint Section

DETAIL NO.:

D31

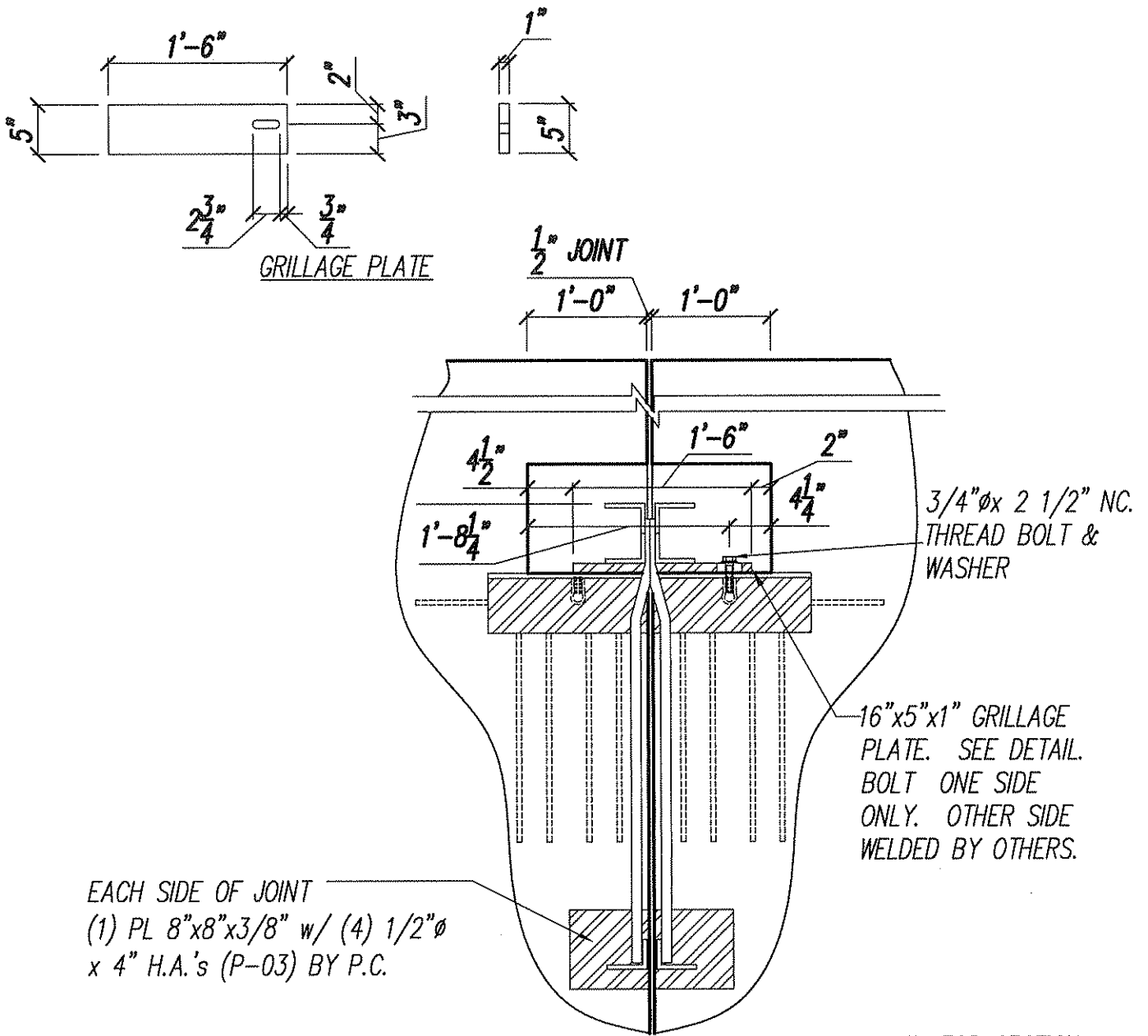

ISSUED: 08/07/08 REVISED:



STANDARD DESCRIPTION:
 Joist Girder Pocket @Joint Detail

DETAIL NO.:
D32